

Three small, square images stacked vertically on the left side of the page. The top image shows a close-up of a metal component with two circular ports. The middle image shows a white rectangular component with various ports and a yellow label. The bottom image shows a cylindrical component with a black cap and a white label.

# Operating Instructions

## Manual Solvent Purification System MB-SPS

Chapter 1 - General Information

Chapter 2 - Safety Information

Chapter 3 - Principles of Operation

Chapter 4 - Installation

Chapter 5 - System Operation

Chapter 6 - Troubleshooting



**Edition Information:**

Edition May 2007

M.Braun, Inc.  
14 Marin Way • Stratham, NH 03885  
Phone 603-773-9333 • Fax 603-773-0008  
Email: info@mbraunusa.com • www.mbraunusa.com

**Revision Information:**

Revision 006

**Title**

Manual Solvent Purification System  
Instruction Manual

**Technical Consultation:**

P. Cardone, Service Department  
T. Daly, Service Department  
R. Mannion, Service Department

**Technical Assistance:**

P. Cardone, Service Department  
T. Daly, Service Department  
R. Mannion Service Department

**Layout:**

B. Adams, Production Department

**Publication edited by means of:**

Adobe Acrobat<sup>®</sup>, Adobe Photoshop<sup>®</sup>, Microsoft Word<sup>®</sup>

**Important Notes:**

This technical documentation is not liable to any obligations on the part of the manufacturer. The manufacturer M.Braun, Inc. reserves the right for technical and optical modifications as well as functional modifications on the system or system's components described therein.

Any duplication of this documentation, even in the forms of excerpts, is only permitted after having obtained the manufacturer's information and concession.



## Chapter 1

### General Information

1.1 Liability....1-1

1.2 Contact Information....1-1

1.3 Entries Referring to the System....1-2

## CHAPTER 1: GENERAL INFORMATION

### 1.1 Liability

The manufacturer is not responsible for personal or secondary damage caused by improper use of the equipment, ignoring of safety instructions or missing updates to the instruction manual after the system and/or its software has been modified. The manufacturer is not responsible for any damages due to loss of data. In addition, the terms of business that are part of the order/contract will apply.

Our products are continuously modified and improved due to innovation, legal requirements and standards. Consequently, the information given in this documentation may not accurately reflect every detail of the system actually delivered. Please contact the manufacturer in cases of uncertainty.

### 1.2 Contact Information

M.Braun, Inc.  
14 Marin Way  
Stratham, NH 03885

Phone:	603-773-9333
Fax (Service Department):	603-773-0008
Email:	<a href="mailto:info@mbraunusa.com">info@mbraunusa.com</a>
Internet:	<a href="http://www.mbraunusa.com">www.mbraunusa.com</a>





## **Chapter 2**

Liability, Warranty  
and Safety

- 2.1 General Information....2-1
- 2.2 Liability....2-1
- 2.3 Warranty....2-2
- 2.4 Operation Guidelines....2-2
- 2.5 Safety - General Hazards....2-2
- 2.6 Safety - Mechanical....2-3
- 2.7 Safety - Electrical....2-4
- 2.8 Chemicals and Gases....2-4
- 2.9 Symbols Used on the System....2-5
- 2.10 Safety - Emergencies....2-6
- 2.11 Additional Information....2-6

## CHAPTER 2: LIABILITY, SAFETY AND WARRANTY





### 2.1 General Information

Prior to installation, initialization and operation of the system, this manual should be read in its entirety and positioned in a suitable area near the system to allow for easy reference. Any persons charged with the transport, storing, installation, commissioning, operating, maintenance and/or service of this system must be familiar with the entire contents of this manual.

To ensure safe operation of the system and to maintain a safe working environment, the information contained within this chapter must be adhered to by all users of the system. Advice contained in this chapter is intended to supplement, not supersede, the safety advice given in other chapters of this manual and the general safety regulations and guidelines prevailing in the user's workplace.

In addition to the guidelines and information contained within this manual all internal and local health, safety and environmental guidelines should be followed.

Safety instructions and pertinent information are marked in the following manner:

	Indicates an imminently hazardous situation which, if not avoided, will result in death, serious injury or serious damage to the system, other equipment or surrounding environment.
	Indicates a potentially hazardous situation which, if not avoided, could result in death, serious injury or serious damage to the system, other equipment or surrounding environment.
	Indicates a potentially hazardous situation which, if not avoided, may result in minor or moderate injury or damage to the system, other equipment or surrounding environment.
	Indicates additional advice or recommendations for using the system or completing a task.

Please consider all instructions, in particular safety instructions, in order to achieve safe operation of the system.

### 2.2 Liability

The manufacturer will not take any liability of object, personal or secondary damage caused by improper use or ignoring of safety instructions as well as caused by the owner's manual due to missing updates after the system has been modified. In addition, the terms of business that are part of the order/contract will apply.

Our products are continuously modified and improved due to innovation, legal requirements and standards. Consequently, the information provided in this documentation may not accurately reflect every detail of the system actually delivered. Please contact the manufacturer in cases of uncertainty.

Products mentioned in this manual are eventually trademarks and are used for identification purposes only.

## 2.3 Warranty

We guarantee the equipment as stated in the order/contract.

This warranty will expire in case of:

- Interference into or modification of the system without prior consent of the manufacturer;
- Improper use of the system;
- Insufficient maintenance of the system;
- Inappropriate operation of the system;
- Negligence of correct supply requirements;
- Application of third-part components to the system without prior consent of the manufacturer;

## 2.4 Operation Guidelines

It is the responsibility of the user to follow all local health, safety and environmental guidelines with regards to the handling and disposing of substances which may be injurious to health.

The following general safety guidelines must be considered when working with inert gas and hazardous solvent concentrations:

- The selected location should have a “room” volume that is significantly larger than the MB-SPS system.
- The system should be located in a well ventilated area. This is especially important when dispensing solvent into a collection vessel.
- All exhaust fumes should be vented through an adequate and appropriately installed disposal/ventilation system.

### NOTICE

Contact M.Braun prior to the acquisition of the system if it is not possible to adhere to all the above recommendations.

Standard MB-SPS systems are designed for the use of most available solvents. Use of these types of solvents must be coordinated with M.Braun prior to the acquisition of a system.

## 2.5 Safety – General Hazards

This system has been designed and manufactured considering all relevant safety regulations. Improper use or operation by persons not qualified accordingly may result in danger to the:

- Life and health of the operator;
- System itself;
- Surroundings of the user;
- Performance and efficiency of the system.

General hazards of the system may arise in the following ways:

- Mechanical hazard caused by squeezing, shearing and cutting, catching and winding, stretching or by freely moving parts;
- Thrust caused by kinetic energy of moving mass;
- Sharp corners and edges;
- Electrical hazard caused by touching live parts (directly or indirectly);
- Thermal hazard causing burns;



- Chemical hazard causing poisoning, corrosion and explosion;
- Toxic hazard due to inhalation of vapours and gases;
- Gases under pressure;
- Liquids under pressure;
- Combination of hazards caused by:
  - faulty installation
  - incorrect loading
  - breakdown of power or media supply
  - breakdown and/or incorrect arrangement of preventive measures
  - combination of escaping media
- Hazards caused by:
  - human misconduct
  - noise
  - allergies, excitations of mucous membrane, unknown effects caused by media
  - ejection of parts
  - disturbance / malfunction of control system
  - leaking of hoses or pipes
  - combination of atmospheres or vapors
  - fire hazard
  - natural hazards e.g. lightning, flooding, environmental catastrophes etc.

## 2.6 Safety – Mechanical



Freely moving parts may cause squeezing, shearing and cutting, catching and winding, stretching of extremities. Extreme caution should be taken to avoid touching any moving parts of the system during operation.

Only genuine parts supplied by M.Braun should be used in the operation of the system. These parts are constructed in conformance with applicable safety regulations. No liability will be taken by M.Braun in the event of installation of parts manufactured by companies other than M.Braun which may result in additional and unknown hazards.

Simultaneous operation of the system by two or more persons is not recommended as this may cause hazards based on misconduct or mutual misunderstanding. In case of the system being operated by two or more persons, operation should be conducted in such a way as to ensure each individual's respective task does not influence other tasks in any way.

Safety covers, panels or doors may not be removed at any time, unless there is a need for service. The system may not be opened during processing or power failures. In the case of any safety deficiencies, the system must be decommissioned and the service personnel informed accordingly. During decommissioning compliance with all local health, safety and environmental guidelines must be followed.

## 2.7 Safety – Electrical

This system operates under high voltage. Risk of injury caused by high voltages exists anytime the system is connected to the power supply, this includes when the system is powered off. Capacitors within the system may be charged when the system is switched off and disconnected from main power supply.



Interchange of current bearing wires can result in electrical hazards such as shock, involuntary muscle reaction, muscle paralysis, burnt tissues and organs, or death.

Opening the system or removing parts when the system is powered on, may result in exposure to live electrical connectors. Extreme caution should be taken to avoid directly or indirectly touching live connectors to avoid possible electric shock.



Prior to performing any electrical service work on the system, ensure the system is powered off and disconnected from the power supply.

Service required while the system is in operation should only be performed only by qualified personnel trained in the knowledge and prevention of all potentially dangerous and hazardous situations.

The system must be grounded/earthed at all times. Do not remove or cut off any ground wire for the system or its components. In case of insufficient grounding or damaged ground conductor ensure the system will be inoperable and secure it against unauthorized or unintentional operation.



Insufficient grounding can cause electrostatic charging of plastic parts, hoses or pipes, wiring and/or the system as a whole, which could cause solvents and process chemicals to ignite.

## 2.8 Safety – Chemicals and Gases

Chemicals used in the system are not supplied by M.Braun. Chemicals are provided and applied by the system user.

Proper handling of chemicals, corrosives and solvents is the user's responsibility. Materials used may be flammable, explosive, toxic.

Below are some guidelines to refer to when handling chemical substances:

- Ensure the all relevant Control of Substance Hazardous to Health (COSHH) guidelines are followed;
- Observe relevant safety regulations as well as material safety data sheets (MSDS) and additional advice provided by the supplier;
- Wear proper protective safety masks, gloves and eyewear whenever working with chemicals, corrosives or solvents;
- Mark all containers and supply lines of chemicals (i.e. containers of media and waste) with appropriate labels and warning signs;
- Ensure proper ventilation and exhaustion of vapors;
- Wear proper breathing protection to avoid the risk of suffocation;
- Keep away from ignition sources;
- Do not smoke;
- Do not ingest food or beverage while working with the chemicals, corrosives or solvents to avoid the risk of poisoning.



Released chemicals may react with each other, leading to unwanted and/or unknown substances, which may cause additional risks.

Proper handling of gases is the user's responsibility. Gases used may be flammable, explosive, toxic. Below are some guidelines to refer to when handling gaseous materials:

- Do not inhale the gas to avoid risk of suffocation.
- Prevent electrostatic charging and beware of ignition sources.
- Do not smoke.



When using corrosive, gassing or noxious materials, the safety of all employees must be ensured by whatever means necessary. Specifically, all employees must be trained in the safe handling of the materials to be used.

## 2.9 Safety – Symbols Used on the System

The following symbols refer to M.Braun components and parts. However, components and parts of sub-suppliers may show other symbols, not expressly mentioned or referred to in this manual. The following caution and command symbols may be seen on the system:



The owner of the system is responsible to place adequate danger signals and labels in suitable places. This applies in particular to signals and labels concerning process chemicals used. Regardless of the number of caution symbols and information placed on or around the system, all safety instructions of this manual must be observed!

## 2.10 Safety – Emergencies

In case of an emergency, please observe the following instructions:

1. Immediately shut off and unplug the vacuum pump.
2. Disconnect the system from all gas supplies.
3. Refer to the material safety data sheets for information on treating the emergency. Contact the appropriate emergency response personnel in the area and/or listed on the material safety data sheets.

Prior to restarting, the system must be fully checked for safety, contact the M.Braun Service Department after the emergency has been rectified.



In addition to the information contained in this manual all local health, safety and environmental guidelines must be followed.

## 2.11 Additional Information

The system is considered to be unsafe for operation if:

- there is any visible damage;
- it fails to perform according to specification;
- it has been subject to prolonged storage under unfavourable conditions;
- it has been subjected to severe transport stress.

If the system meets any or all of the above:

- make it inoperable;
- secure it against any unauthorized or unintentional operation;
- contact the M.Braun Service Department.



Do not perform any service or repair of the system or its components other than described in this manual.



Maintenance, repair and service other than described in this manual may only be performed by M.Braun service personnel or properly trained/qualified individuals.



## **Chapter 3**

### Principles of Operation

3.1 Description of the System....3-1

3.2 Method....3-1

ОБЕРЯТІНГ ІНСТРУКЦІЇ

## CHAPTER 3: PRINCIPLES OF OPERATION

### 3.1 Description of the System

The M.Braun Solvent Purification System (MB-SPS) is a fully enclosed system which has the capability to purify up to 7 solvents and can be used as a stand-alone unit or integrated with a glovebox.



The MB-SPS removes oxygen and moisture from a wide range of organic and deuterated solvents quickly and safely. Purified solvents are dispensed by means of the valves, located on the front of the system or plumbed into a glovebox, directly into the user's choice of collection vessel. Solvents are dispensed into a collection vessel from the spigot hood located on the front of the system under anaerobic conditions. Solvents can also be dispensed into a collection vessel located inside a glovebox directly into an inert environment.

Stainless steel purifier columns, located inside the system are equipped with pre-filters and activated prior to shipment of the MB-SPS. The system is capable of purifying up to 800 liters of solvent before service or replacement is required. The user is responsible for disposing of exhausted purifier columns according to all local, state and federal guidelines.

### 3.2 Method

The solvent reservoir is pressurized forcing the inert gas supply (typically a nitrogen source of 99.99% purity or better) through the HPLC grade solvent to be sparged for a period of twenty minutes to remove the oxygen. The degassed solvent is then stored in the solvent reservoir.

When dispensing, the solvent is forced under low pressure from the reservoir through a circuit of two gas tight desiccant columns which remove the moisture from the solvent. The solvent is then dispensed into a collection vessel free of oxygen and moisture.

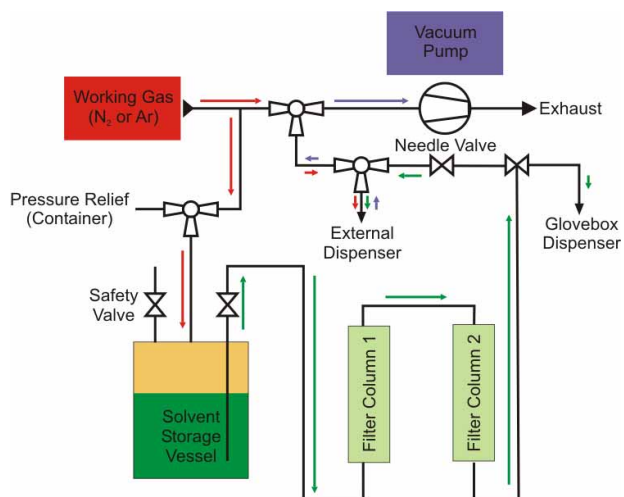

## **Chapter 4** Installation

- 4.1 Tools and Materials Required....4-1
- 4.2 General Information....4-1
- 4.3 Attaching the Nitrogen Supply Line....4-2
- 4.4 Filling the Solvent Reservoirs....4-3
- 4.5 Degassing the Reservoir....4-9
- 4.6 Commissioning the System....4-10





## CHAPTER 4: INSTALLATION

### 4.1 Tools and Materials Required

Below you will find the listing of tools and materials required to install the MB-SPS. None of the tools listed are supplied by M.Braun. The materials listed are supplied by M.Braun with the exception of the nitrogen supply and stopper.

#### Tools:

- 11/16" Wrench
- 5/16" Wrench
- 5/8" Wrench
- Flathead Screwdriver
- Phillips Head Screwdriver
- Adjustable Wrench

#### Material

- Nitrogen Supply (99.99% purity or better)
- 3/8" Tygon Tubing – 20 foot length with adjustable hose clamp, hose barb and 3/8" Swagelok® fitting connected on one end
- 1/4" PTFE Tubing – (1) 1 foot length with a 1/4" Swagelok® union on one end
- 1 Two Hole Rubber Bottle Stopper
- Adjustable hose clamp
- Braided Hose with Female Quick Connect
- Braided Hose with Male Quick Connect

### 4.2 General Information

The Manual Solvent Purification System comes complete and ready to operate with the exception of the Nitrogen valve and supply line and the solvent reservoirs (Figures 4.1 and 4.2). The following sections provide instructions for attaching the Nitrogen supply line and filling the reservoirs. Step-by-step pictures are included for reference.

Any questions that arise during the installation process should be directed to the M.Braun Service Department.



Figure 4.1 - Nitrogen Regulator and Inlet



Figure 4.2 - Solvent Reservoir



### 4.3 Attaching the Nitrogen Supply Line

Follow the instructions below to attach the supplied length of Tygon tubing from the Nitrogen supply to the system.

Locate the Valve Operation Line Regulator located on the right side of the system above the vacuum pump.



Insert the Tygon tubing into the connector on the regulator.



Using a flathead screwdriver, tighten the adjustable hose clamp until snug.



## 4.4 Filling the Solvent Reservoirs

### General Information

The following information provides instructions for filling the solvent reservoir(s) using a pour method or vacuum transfer. Whenever the solvent reservoirs are refilled the steps described in Chapter 7.2 must be performed prior to dispensing solvent for use.

Before attempting to use a different type of solvent reservoir than what is supplied with the system contact the M.Braun Service Department to ensure compatibility with the system.

Please contact the M.Braun Service Department with any questions regarding the instructions included below.



Because only one of each type of braided hoses used for filling and degassing the reservoirs is supplied with the system, they should be purged after each use to avoid cross contamination between solvents. Additional hoses can be purchased, please contact the M.Braun Service Department for more information.



- The reservoir should be filled with no more than 17 liters of solvent at one time.
- Before using the cylinder it is necessary to perform the degas procedure.



Only inhibitor free THF solvent can be used in the MB-SPS system. Failure to do so will result in polymerization of the columns.

### Valve and Line Types

Below are two views of the solvent reservoir. Please refer to these pictures when following the instructions.



Figure 4.3 - Top View



Figure 4.4 - Front View

- A. Over Pressure Valve
- B. Solvent Supply Line
- C. Nitrogen Push Line
- D. Dip Tube Assembly and Clamp

## Filling the Reservoir – Pour Method

Remove the Nitrogen Push Line (C) by pulling on the ribbed area until it releases and lift off.

Disregard this line until after the reservoir is filled with solvent.



Remove the Solvent Supply Line (B) by pushing on the ribbed area until it releases and lift off.

Disregard this line until after the reservoir is filled with solvent.



Remove the Dip Tube Assembly Clamp (D) by loosening the wing nut in a counterclockwise direction until the clamp can be freed from the flange.



Carefully remove the dip tube assembly and o-ring.



Fill the reservoir with solvent.



Carefully replace the o-ring and dip tube assembly.



Place the clamp around the flange, making sure the dip tube assembly is seated properly.

Tighten the clamp by turning the wing nut in a clockwise direction.



### Filling the Reservoir – Vacuum Transfer Method



Because only one of each type of braided hoses used for filling and degassing the reservoirs is supplied with the system, they should be purged after each use to avoid cross contamination between solvents. Additional hoses can be purchased, please contact the M.Braun Service Department for more information.

Deactivate the vacuum pump.

Remove the Nitrogen Push Line (C) by pulling on the ribbed area until it releases and pull off.

Disregard this line until after the reservoir is filled with solvent.



Remove the Solvent Supply Line (B) by pushing on the ribbed area until it releases and pull off.

Disregard this line until after the reservoir is filled with solvent.



Attach the provided braided hose with the female quick connector to the Nitrogen Push connector on the dip tube assembly by pushing on the ribbed area until it clicks into place.



Remove the 1/4" plug from the vacuum source intake.

Attach the other end of the tubing to the vacuum source intake.

Turn the fitting in a clockwise motion and tighten until finger tight. Use an adjustable wrench to tighten 1/4 turn more.



## NOTICE

The vacuum supply to be used can any of the following:

- Facility Vacuum System
- System Vacuum Pump
- Other Vacuum Pump

Attach the provided braided hose with the male quick connector to the Solvent Supply Line connector on the dip tube assembly by pulling on the ribbed area until it clicks into place.



Attach the PTFE to the other end of the braided hose connected to the Solvent Supply line using the 1/4" Swagelok® union.

Turn the fitting in a clockwise motion and tighten until finger tight. Use an adjustable wrench to tighten 1/4 turn more.



Place the other end of the other length of 1/4" PTFE tubing in one hole of the bottle stopper leaving the other hole open.



Put the stopper into the opening of the bottle to be used.  
Push the tube through the stopper into the container until it reaches the bottom.



Activate the vacuum source.



Monitor the solvent level in the bottle while the solvent is being dispensed into the reservoir.

Deactivate the vacuum source.

Remove the stopper from the bottle.



Remove the provided braided hose with the male quick connector from the Solvent Supply Line connector on the dip tube assembly by pushing on the ribbed area until it releases.



Remove the provided braided hose with the female quick connector from the Nitrogen Push connector on the dip tube assembly by pulling on the ribbed area until it releases.



Reattach the Nitrogen Push Line (C) by pushing on the ribbed area until it clicks into place.



Reattach the Solvent Supply Line (B) by pulling on the ribbed area until it clicks into place.



Repeat this process with the remaining solvents.



## 4.5 Degassing the Reservoir

After the reservoir has been filled, it is necessary to perform a degas procedure. This must be done every time a reservoir is filled with solvent regardless of the method used to fill it.



Because only one of each type of braided hoses used for filling and degassing the reservoirs is supplied with the system, they should be purged after each use to avoid cross contamination between solvents. Additional hoses can be purchased, please contact the M.Braun Service Department for more information.

Deactivate the main gas supply.



Solvent reservoir degas valve should be vented to a fume hood when degassing the solvents.

Use only PTFE tubing to connect the degas valve to the fume hood. Failure to use this type of tubing can cause breakdown of the tubing resulting in contaminated solvent.

Remove the Nitrogen Push Line (C) by pulling on the ribbed area until it releases and pull off.

Disregard this line until after the reservoir is filled with solvent.



Remove the Solvent Supply Line (B) by pushing on the ribbed area until it releases and pull off.

Disregard this line until after the reservoir is filled with solvent.



Attach the provided braided hose with the male quick connector to the Solvent Line connector on the dip tube assembly by pulling on the ribbed area until it clicks into place.



Remove the ¼" plug from the nitrogen regulator intake supply line and attach the other end of the tubing to the nitrogen regulator intake supply line.

Turn the fitting in a clockwise motion and tighten until finger tight. Use an adjustable wrench to tighten ¼ turn more.



Attach the provided braided hose with the female quick connector to the Nitrogen Push connector on the dip tube assembly by pushing on the ribbed area until it clicks into place.



Attach the other end of the braided line to a fume hood or other appropriate ventilation system.

Turn on the gas supply to a pressure of 5 – 7 psi.

Degas the solvent for a minimum of thirty (30) minutes.

Turn off the gas supply.

Remove the supplied lines, reattach the lines connected to the system and repeat the process with the remaining solvents.

## 4.6 Commissioning the System

Prior to the initial use of the system, it is necessary to flush each solvent line of any impure solvent. Flushing the lines should also be performed any time the filter columns (or the filter material) are replaced.

Plug the vacuum pump (115V 15amp) plug into the main power supply.



Turn on the gas supply to a pressure of 5-10 psi.





Starting with Solvent 1, place a waste collection vessel under the solvent dispenser.



Slowly turn the bottom valve to the **Dispense** position until a steady stream of solvent flows into the vessel.

The top valve should remain in the **Neutral** position.

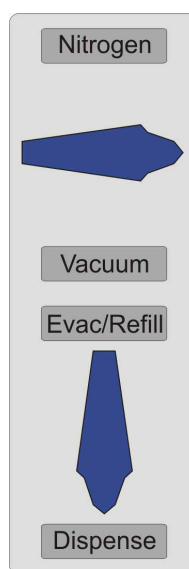

Fill the waste collection vessel with 300ml of solvent.

Slowly turn the bottom valve to the **Evac/Refill** position and the top valve to the **Nitrogen** position.

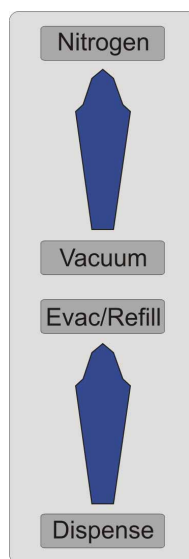

Wait a minimum of 5 – 10 seconds or until solvent ceases flowing into the vessel.

Discard the waste solvent accordingly and repeat the process for the remaining solvents.



## Chapter 5

### System Operation

5.1 General Information....5-1

5.2 Evacuation of the Collection Vessel...5-2

5.3 Dispensing Solvent....5-4

5.4 Clearing the Solvent Line....5-5

## CHAPTER 5: SYSTEM OPERATION

### 5.1 General Information

Dispensing solvent is performed using a three step process. The first step involves evacuating the collection vessel to create an anaerobic environment. The second step is the actual dispensing. Step three clears the line so solvent does not remain stored in the dispensing line while the system is not in use.

The flow of solvents during dispensing is regulated using the bottom valve on the front of the system (Figure 5.1). The valves are color coded to correspond to the solvent reservoirs and cylinders.



Figure 5.1 – Solvent Dispensing Manifold

#### NOTICE

The flow rate of solvent during dispensing is regulated by the position the valve is put in. Maximum flow is achieved when the valve is put in the 6 o'clock (fully open) position. Flow will begin when the valve is put in approximately the 4 o'clock position.

#### CAUTION

Always turn the valve handles using a slow steady motion. Turning valves too quickly may result in damage to the system or equipment and/or injury to the user.

## 5.2 Evacuating the Collection Vessel

Prior to dispensing solvent, the collection vessel must be evacuated three (3) times. Follow the steps below to evacuate the collection vessel.



- The collection vessel to be used should be able to withstand the vacuum state.
- Never evacuate a glass collection vessel when there is liquid solvent present in the vessel.

Place a collection vessel under the solvent dispenser to be used.

Make sure the vessel is adequately secured by holding it in place or using a cork ring or other laboratory lifting platform.



Turn bottom valve to the **Evac/Refill** position and turn the top valve to the **Vacuum** position.

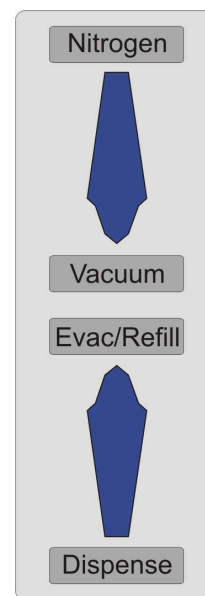

Leave the valves in this position and evacuate the vessel for a minimum of 90 seconds.

**NOTICE**

Evacuation times will vary depending on the size of the collection vessel.

Turn the top valve towards **Nitrogen** and hold it at the **1 o'clock** position for 2 – 5 seconds.

Turn the valve slowly to prevent a sudden burst of Nitrogen into the vessel.

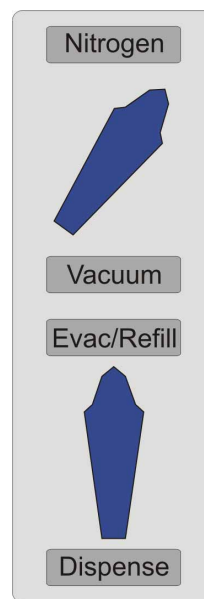

Repeat the evacuation and backfill process a second time.

Evacuate the vessel a third time.

Turn the top valve to the **Neutral** position.

The bottom valve should remain in the **Evac/Refill** position.

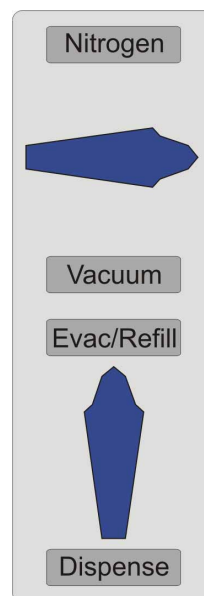

After the third (3<sup>rd</sup>) evacuation process is complete, the solvent can be dispensed for use.

Do NOT remove the collection vessel.

## 5.3 Dispensing Solvent

Follow the steps below to dispense solvent into the collection vessel after performing the evacuation.



The collection vessel should never be filled to a level more than  $\frac{3}{4}$  of the actual capacity. Filling the vessel to a higher level may result in overpressurization which could cause the collection vessel to overflow.

Turn the top valve to the **Neutral** position (if it is not already in this position from the evacuation process).

Turn the bottom valve to the **Dispense** position. This will start the flow of solvent into the collection vessel.

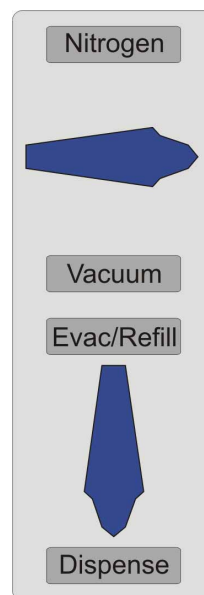

### NOTICE

The flow rate of solvent during dispensing is regulated by the position the valve is put in. Maximum flow is achieved when the valve is put in the 6 o'clock (fully open) position. Flow will begin when the valve is put in approximately the 4 o'clock position.

After the desired amount of solvent has been dispensed turn the bottom valve to the **Evac/Refill** position.

Turn the top valve towards **Nitrogen** and hold it at the **1 o'clock** position for 2 – 5 seconds. This will clear the line of solvent and backfill the collection vessel with nitrogen.

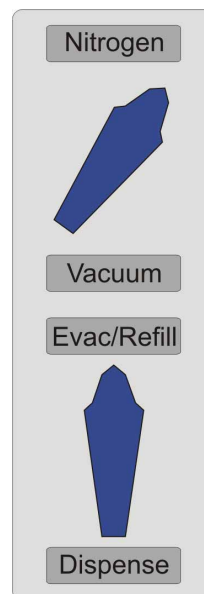

Turn the top valve back to the **Neutral** position.

The bottom valve should remain in the **Evac/Refill** position.

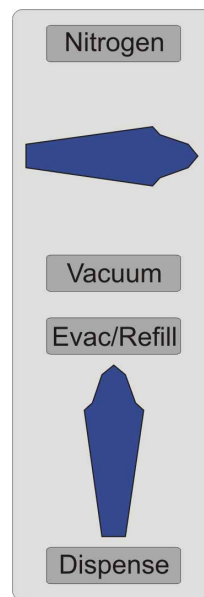

## 5.4 Clearing the Solvent Dispensing Line

Follow the steps below to clear the dispensing line of any residual solvent to aid in avoiding possible cross contamination.

Remove the solvent collection vessel and place a waste collection vessel under the solvent dispenser.



Turn the bottom valve to the **Evac/Refill** position.

Turn the top valve to the **Nitrogen** position.

Leave the valves in this position for 30 seconds to 1 minute.

The times shown are minimum requirements. The valves should remain in these positions until no more solvent is dispensed.

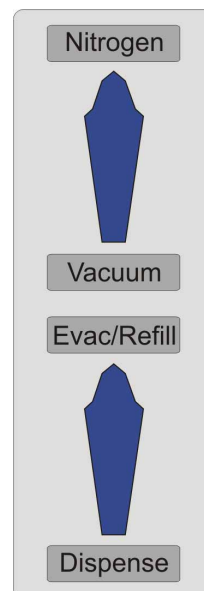

Turn the top valve to the **Neutral** position.

Turn the bottom valve to the **Neutral** position.

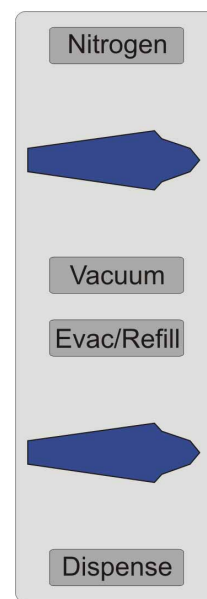

Remove the waste collection vessel and dispose of the solvent accordingly.



## **Chapter 6**

Troubleshooting

- 6.1 General Information...6-1
- 6.2 Solvent Flow...6-1
- 6.3 Solvent Reservoir...6-1
- 6.4 Solvent Dispensing...6-2



## CHAPTER 6: TROUBLESHOOTING

### 6.1 General Information

This chapter provides general information for troubleshooting various issues which may be encountered during operation of the system. For information regarding troubleshooting of vendor manufactured components, please consult the vendor supplied user manuals.

#### NOTICE

Contact the M.Braun Service Department with questions regarding any of the troubleshooting steps listed below.

### 6.2 Solvent Flow

If the solvent flow is sporadic or slow the catalyst bed in the purifier column may not be completely saturated. Follow the steps below to find and correct the possible cause.

Dispense a minimum of 500ml of solvent into the collection vessel.	Did the solvent flow increase? Yes – continue normal operation No – proceed to next step
Check the pressure reading on the Nitrogen regulator. Ensure the pressure is set to 5psi.	Did the solvent flow increase? Yes – continue normal operation No – contact M.Braun Service Department

### 6.3 Solvent Reservoir

If there is evidence of solvent odor when there is no dispensing in process or if some time has elapsed since the reservoirs have been filled, follow the steps below to find and correct the possible cause.

Check the dip tube assembly to make sure it is seated correctly. Adjust as necessary.	Did this fix the problem? Yes – continue normal operation No – proceed to next step
Is the clamp tightened hand tight? Adjust as necessary.	Did this fix the problem? Yes – continue normal operation No – proceed to next step
Check to see if the system pressure is reading below 15psi. If the pressure is above 15psi, the pressure relief valve will be open releasing solvent vapor to relieve the pressure inside the system. Adjust the pressure as needed.	Did this fix the problem? Yes – continue normal operation No – contact M.Braun Service Department

## 6.4 Solvent Dispensing

If no solvent is released during the dispensing process, follow the steps below to find and correct the possible cause.

<p>Check the Nitrogen regulator to make sure the pressure is set between 5psi and 10psi.</p>	<p>Did this fix the problem?          Yes – continue normal operation          No – proceed to next step</p>
<p>Check the positions of the all the solvent routing valves. Adjust as necessary.</p>	<p>Did this fix the problem?          Yes – continue normal operation          No – proceed to next step</p>
<p>Check the positions of all the solvent reservoir lines. Adjust as necessary.</p>	<p>Did this fix the problem?          Yes – continue normal operation          No – proceed to next step</p>
<p>Check the level of solvent inside the reservoir. Adjust as necessary.</p>	<p>Did this fix the problem?          Yes – continue normal operation          No – contact M.Braun Service Department</p>