

Agilent 5100 and 5110 ICP-OES

Site Preparation Guide



Agilent Technologies

Notices

© Agilent Technologies, Inc.
2014, 2016, 2017, 2019

No part of this manual may be reproduced in any form or by any means (including electronic storage and retrieval or translation into a foreign language) without prior agreement and written consent from Agilent Technologies, Inc. as governed by United States and international copyright laws.

Manual Part Number

G8010-90001

Edition

Fifth edition, February 2019

Agilent Technologies, Australia (M)
Pty Ltd
679 Springvale Road
Mulgrave, Victoria, 3170
Australia

www.agilent.com

Warranty

The material contained in this document is provided “as is,” and is subject to being changed, without notice, in future editions. Further, to the maximum extent permitted by applicable law, Agilent disclaims all warranties, either express or implied, with regard to this manual and any information contained herein, including but not limited to the implied warranties of merchantability and fitness for a particular purpose. Agilent shall not be liable for errors or for incidental or consequential damages in connection with the furnishing, use, or performance of this document or of any information contained herein. Should Agilent and the user have a separate written agreement with warranty terms covering the material in this document that conflict with these terms, the warranty terms in the separate agreement shall control.

Technology Licenses

The hardware and/or software described in this document are furnished under a license and may be used or copied only in accordance with the terms of such license.

Restricted Rights Legend

If software is for use in the performance of a U.S. Government prime contract or subcontract, Software is delivered and licensed as “Commercial computer software” as defined in DFAR 252.227-7014 (June 1995), or as a “commercial item” as defined in FAR 2.101(a) or as “Restricted computer software” as defined in FAR 52.227-19 (June 1987) or any equivalent agency regulation or

contract clause. Use, duplication or disclosure of Software is subject to Agilent Technologies’ standard commercial license terms, and non-DOD Departments and Agencies of the U.S. Government will receive no greater than Restricted Rights as defined in FAR 52.227-19(c)(1-2) (June 1987). U.S. Government users will receive no greater than Limited Rights as defined in FAR 52.227-14 (June 1987) or DFAR 252.227-7015 (b)(2) (November 1995), as applicable in any technical data.

Safety Notices

CAUTION

A **CAUTION** notice denotes a hazard. It calls attention to an operating procedure, practice, or the like that, if not correctly performed or adhered to, could result in damage to the product or loss of important data. Do not proceed beyond a **CAUTION** notice until the indicated conditions are fully understood and met.

WARNING

A **WARNING** notice denotes a hazard. It calls attention to an operating procedure, practice, or the like that, if not correctly performed or adhered to, could result in personal injury or death. Do not proceed beyond a **WARNING** notice until the indicated conditions are fully understood and met.

Request for Installation

All preparations have been completed. Please arrange for the installation to be completed as soon as possible. I understand that if the installation site is not prepared in accordance with the enclosed instructions, additional installation charges may apply.

Company name: _____

Company address: _____

Name: _____

Position: _____

Telephone: _____

Preferred installation date: _____

Signed: _____

Date: _____

Site Preparation Checklist

Site Preparation Checklist

Your site must meet all requirements before you request installation. Complete each requirement listed in the table. After completing each requirement, place a check in the appropriate check box. Ensure you compare the boxes with the shipping list supplied with the boxes.

Requirements	<input checked="" type="checkbox"/>
Principal installation area is in compliance with all relevant safety regulations.	<input type="checkbox"/>
Laboratory temperature is maintained between 15-30°C (59-86°F)	<input type="checkbox"/>
Laboratory is free of excessive particulate matter.	<input type="checkbox"/>
Cooling air system is set up (if required).	<input type="checkbox"/>
Workbench requirements are met.	<input type="checkbox"/>
Sufficient bench space is available for all components.	<input type="checkbox"/>
Bench can support system weight.	<input type="checkbox"/>
Personal computer with Microsoft Windows 7 Professional 64-bit SP1 or Microsoft Windows 10 Professional installed and printer is set up, if purchased separately.	<input type="checkbox"/>
Exhaust system is suitable and installed.	<input type="checkbox"/>
Specified electrical supply and power outlets are installed.	<input type="checkbox"/>
Gas supply (at specified purity), regulator, and gas lines are installed for argon and any allowed optional gases.	<input type="checkbox"/>
Water cooling/circulation system and power connections are set up, if system is not purchased from Agilent.	<input type="checkbox"/>
Waste container appropriate for the chemical waste is prepared.	<input type="checkbox"/>
Accessories Purchased	
SPS 4 Autosampler	<input type="checkbox"/>
SPS 3 Sample Preparation System	<input type="checkbox"/>
Advanced valve system (AVS) 4, 6, or 7 Switching Valve	<input type="checkbox"/>
SVS 2+ Productivity Package	<input type="checkbox"/>
VGA Vapor Generation Accessory	<input type="checkbox"/>
5 Channel Peristaltic Pump	<input type="checkbox"/>
Air Inlet Duct Filter	<input type="checkbox"/>
External Inlet Duct Adapter	<input type="checkbox"/>
Multimode Sample Introduction System (MSIS)	<input type="checkbox"/>
Argon Saturator Accessory (ASA)	<input type="checkbox"/>
IsoMist™ Programmable Temperature Spray Chamber	<input type="checkbox"/>

Contents

Request for Installation	3
Site Preparation Checklist	4
1. Safety Practices and Hazards	7
Heat, Vapors and Fumes	7
Compressed Gas Hazards	7
Electrical Hazards	8
Other Precautions	8
2. Introduction	9
Installation Guidelines	9
3. Laboratory Environment	11
Environmental Conditions	11
Installation category	11
Pollution level	11
Temperature Control	12
Cleanliness	12
Instrument Cooling Air Supply	12
Workbench	13
Location	14
PC Requirements	17
4. Instrument Shipping Information	19
Weights and Dimensions	19

Safety Practices and Hazards

Seismic Requirements	20
5. Laboratory Facilities	23
Exhaust System	23
Electrical Power Supplies	25
Electrical Requirements	26
Single phase requirement	26
Power plugs and cords	27
Gas Supplies	27
Water Chiller System	30
Location	31
Waste Fluid Container	32
Guidelines for Software Installation	32
6. Accessories and Options	34
Vapor Generation Accessory (VGA) Recommended Gases	34
Important Customer Web Links	35
Appendix A: Power Cords	36

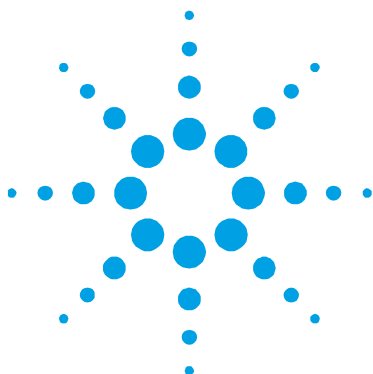

1. Safety Practices and Hazards

Heat, Vapors and Fumes

Heat, ozone, vapors and fumes generated by the plasma can be hazardous, and must be extracted from the instrument by means of an exhaust system. Ensure that an exhaust system of the appropriate type is fitted (see Page 23). The system must be vented to the outside air in accordance with local regulations and never within the building. Regularly check the exhaust system by smoke test to ensure that the exhaust system is functioning correctly. The exhaust fan must always be switched on *before* igniting the plasma.

Compressed Gas Hazards

All compressed gases (other than air) can create a hazard if they leak into the atmosphere. Even small leaks in gas supply systems can be dangerous. Any leak (except that of air or oxygen) can result in an oxygen-deficient atmosphere, which can cause asphyxiation. The area in which cylinders are stored and the area surrounding the instrument must be adequately ventilated to prevent such gas accumulations.

Gas cylinders must be installed, stored and handled strictly in accordance with local safety codes and regulations. Cylinders must be used and stored only in a vertical position and secured to an immovable structure or a properly constructed cylinder stand. Move cylinders only by securing them to a properly constructed trolley.

Use only approved regulator and hose connectors (refer to the gas supplier's instructions).

Safety Practices and Hazards

Use only 'instrument grade' gases with your spectrometer.

If using cryogenic gases (for example, liquid argon), prevent severe burns by wearing suitable protective clothing and gloves.

Electrical Hazards

Connecting the Agilent ICP-OES to a power source that is not equipped with a protective earth contact creates a shock hazard for the operator and can damage the instrument. Likewise, interrupting the protective conductor inside or outside the Agilent ICP-OES or defeating the power cord ground creates a shock hazard for the operator and can damage the instrument.

Other Precautions

Air flow to the cooling fans of the spectrometer and accessories must be unobstructed. Do not block the ventilation grills on the spectrometer and accessories. Consult the manuals supplied with your PC, monitor, printer and water-cooling system for their specific ventilation requirements.

The spectrometer weighs approximately 106 kg (234 lb). To avoid injury to personnel or damage to the instrument or property, always use a forklift or other suitable mechanical lifting device to move the instrument.



After all safety regulations have been met, check the checklist box: *Principal installation area is in compliance with all relevant safety regulations.*

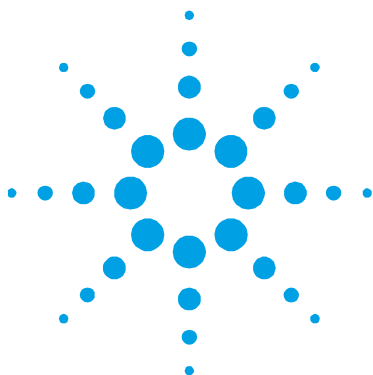

2. Introduction

This publication contains the information required to successfully prepare a site for an Agilent ICP-OES system installation.

On completion of the site preparation, fill in the checklist on Page 4, (striking out those entries not applicable), and send this checklist to your local Agilent agent or Agilent sales and service office. As soon as it is received, Agilent or its agent will contact you to arrange a convenient time for installation.

If you have difficulty in preparing for the installation, and for details of operator training courses, please contact your Agilent sales or field service representative.

Installation Guidelines

Allow a minimum of one day for the installation of the Agilent ICP-OES system by an Agilent field service engineer.

The installation will include the following:

- Spectrometer installation
- Water chiller connection
- Instrument software installation and registration
- Accessory installation
- Spectrometer installation performance tests
- Basic customer training
- Maintenance overview

Introduction

This page is intentionally left blank.



3. Laboratory Environment

Environmental Conditions

The Agilent ICP-OES instrument is suitable for indoor use *only* and is classified suitable under Equipment class I category.

Installation category

The installation category is II, based on IEC61010-1. The installation category implies the regulation for impulse withstand voltage. It is also called the ‘Over voltage category’. ‘II’ applies to electrical equipment with a nominal supply voltage up to 300 V.

Pollution level

The pollution level is 2, based on IEC61010-1. Pollution level describes the degree to which a solid, liquid or gas that deteriorates dielectric strength is adhering. ‘2’ applies to a normal indoor atmosphere, where only non-conductive pollution occurs.

Table 1. Suitable environmental conditions for the ICP-OES instruments

Condition	Altitude	Temp. (°C)	Humidity (%RH) non-condensing
Non-operating (Storage)	0–3000 m (0–9840 ft)	5–60	15–85
Operating within specifications	0–3000 m (0–9840 ft)	15–30	20–80

Laboratory Environment

Temperature Control

Air-conditioning is strongly recommended for control of the environment.

NOTE

For *optimum analytical performance*, it is recommended that the ambient temperature of the laboratory be between 20 and 25 °C (68 and 77 F), and be held constant to within ± 2 °C (± 3.6 °F) throughout the entire working day.

The ICP-OES spectrometer generates 870 watts maximum (joules per second) or 3132 kilojoules per hour (2968 BTU per hour).

The water chiller generates approximately 2000 watts maximum (joules per second), or 7200 kilojoules per hour (6824 BTU per hour).



After the temperature requirements have been met, check the checklist box: *Lab temperature maintained between 15 and 30 °C.*

Cleanliness

The area selected for the operation of an Agilent ICP-OES system *must be free from drafts, corrosive atmospheres and vibration* and should be a dust-free, low humidity environment.

Sample preparation areas and materials storage facilities should be located in a separate room.

Limit dust levels to less than 36,000,000 particles (0.5 microns or larger) per cubic meter of air. This is equivalent to a very clean office.



After the cleanliness requirements have been met, check the checklist box: *Laboratory is free of excessive particulate matter.*

Instrument Cooling Air Supply

The Agilent ICP-OES instrument requires *clean, dry, non-corrosive air for cooling purposes*. This is supplied to the instrument through an air supply vent located at the top, front of the instrument. The vent is fitted with a dust filter, to filter out particulate matter from the surrounding environment.

The air supply is used to cool the RF generator and the electronics of the instrument. Several of these assemblies contain parts prone to corrosion. The introduction of cooling air contaminated with high levels of acid vapor or other corrosive substances may cause damage to the instrument.

Due to the corrosive nature of some analytical work, it is recommended that in applications demanding high usage of corrosive materials, an external cooling air supply system be provided. It is *strongly recommended* that the cooling air be supplied from an environmentally controlled area that is away from the instrument exhaust and any other area where corrosive materials are stored or used. Do not duct humid, warm air into an instrument in a cooled laboratory environment.

The external cooling air system with flue, fan, and ducting must provide a minimum positive flow of 4 m³/minute (141 ft³/min) to the instrument when using the External Inlet Duct Adaptor Kit (G8010-68002). The ducting should be corrosion resistant and fire-proof.

NOTE

If an external cooling air supply system is required, an air inlet duct attachment must be ordered with the instrument.



After the instrument cooling air supply requirements have been met, check the checklist box: *Cooling air system is set up.*

Workbench

The Agilent ICP-OES is a precision optical instrument. The workbench must be free from vibration and must be stable and strong enough to support the total weight of the equipment to be placed on top of the workbench. The bench top should be large enough to permit free circulation of air through the main instrument and around each of the accessories.

The information provided in the weights and dimensions table will help make planning easier. Portable or semi-permanent trolleys can be used as workbenches for the spectrometer system, but you must *lock* the wheels. Accessories such as the Sample Preparation System (SPS) Autosampler, PC and printer can be positioned on a trolley. A specially designed SPS trolley is available from Agilent.

Laboratory Environment

To avoid damage through spillage of samples being used, the instrument bench top should be covered with a material that is corrosion-resistant and impervious to liquid spillage. Generally, for comfortable working conditions and easy access to the instrument sample introduction system, Agilent recommends that the height of the workbench be approximately 900 mm (36 in) high. Refer to Figure 1.

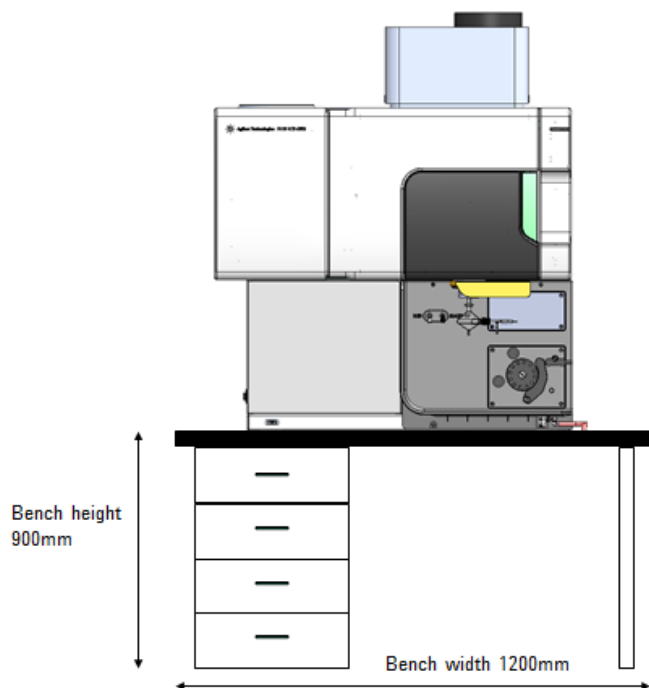

Figure 1. Instrument workbench

Location

The workbench location should permit service access from all sides.

Position the equipment for easy access to the power switch and for disconnecting the power cable on the left side of the instrument. A minimum of 400 mm (16 in) free space at the sides of the spectrometer and approximately 30 mm (1.2 in) at the rear of the instrument is required for maintenance and service access. Leave enough space in front and to the left side of the instrument to provide easy access to the mains power on/off switch at all times.

The ICP-OES system should not be located close to an access door, window or any other area where drafts may cause fluctuating temperature conditions.

The following diagrams show the relative dimensions of the main instrument including the space needed for service access. These dimensions should be considered during the preparation for installation of your spectrometer.

The location of the workbench may be determined by the position of the exhaust flue required to remove fumes and vapors from the spectrometer sample compartment (see Section 5).

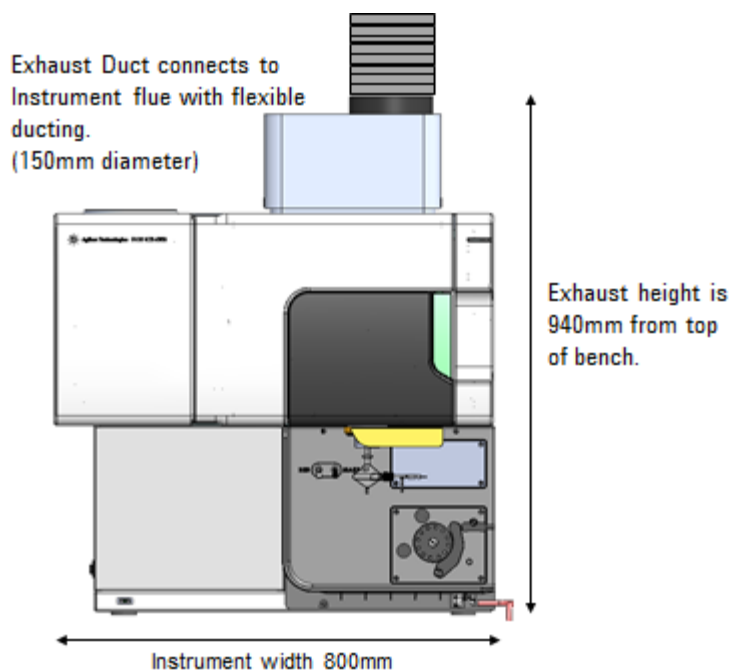

Figure 2. Front view of instrument

Laboratory Environment

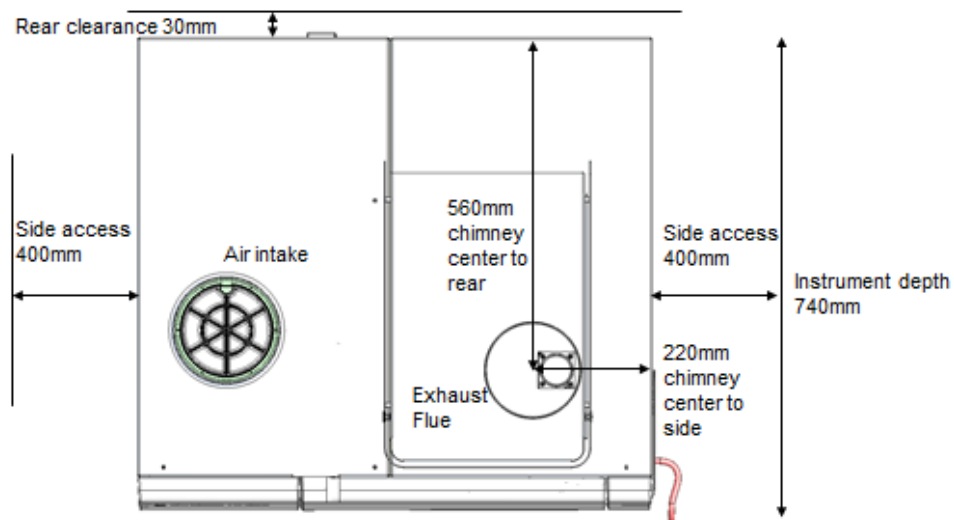

Figure 3. Top view of instrument

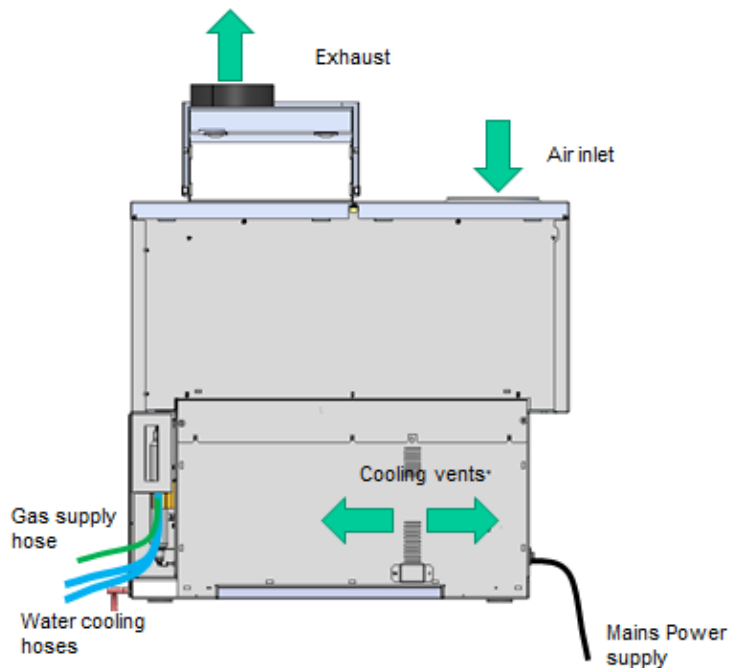

Figure 4. Rear view of instrument

- ☑ After the workbench vibration and location requirements have been met, check the checklist box: *Workbench requirements met.*
- ☑ After the bench space requirements have been met, check the checklist box: *Sufficient bench space is available for all components.*
- ☑ After the bench support requirements have been met, check the checklist box: *Bench can support system weight. See Page 19 for Weight and Dimension information.*

PC Requirements

The minimum configuration represents the absolute minimum you can run the software on. This PC configuration may be out of manufacture, but you may want to use a PC you already have. The recommended configuration is that which you would buy new.

Table 2. PC requirements

Minimum	Recommended
2 GHz 64-bit (x86) quad core processor or higher	3.2 GHz 64-bit (x86) quad core processor or higher
4 GB of system memory	8 GB of system memory
120 GB hard drive with at least 15 GB of available space	500 GB hard drive
DVD-ROM Drive	DVD-ROM Drive
Screen resolution of 1280x768 running in 96 dpi	22 inch screen with minimum screen resolution of 1920x1080 running in 96 dpi
Ethernet port	Ethernet port
Two USB 2.0 ports	4 USB 3.0 ports 6 USB 2.0 ports
Windows 7 Professional 64-bit or Windows 10 Professional 64-bit	Windows 7 Professional 64-bit or Windows 10 Professional 64-bit

Higher rated PC components can be substituted for those listed above for example, processor type, amount of memory, screen size and resolution and operating system version.

This page is intentionally left blank.

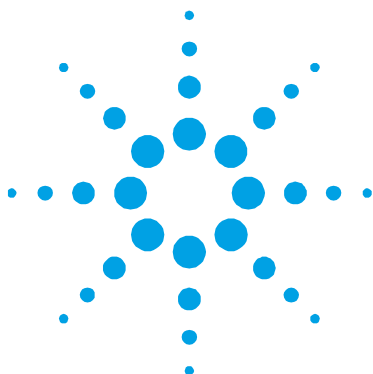

4. Instrument Shipping Information

Due to the size and nature of the spectrometer, it is advisable that a third party is engaged to assist with transportation from the point of unloading to the final placement of the instrument in the laboratory. The Agilent field Sales and Service Offices will be able to assist in the task of recommending a third party that specializes in the transportation of precision scientific instrumentation.

NOTE

Do not open any of the ICP-OES or accessory boxes unless otherwise specified by an Agilent field service engineer.

The required turning and door clearance may need to take into consideration any lifting device used for transporting the instrument (for example, fork lift, pallet truck or trolley).

Weights and Dimensions

Table 3. Weights and dimensions

System unit	Width	Depth	Height	Weight
Agilent ICP-OES instrument	800 mm (31 in)	740 mm (29.5 in)	940 mm (39 in)	106 kg (234 lb)
Shipping dimensions	945 mm (37.2 in)	910 mm (35.8 in)	1225 mm (48.2 in)	152 kg (335.1 lb)
Personal computer (typical)	450 mm (18 in)	770 mm (30 in)	520 mm (20 in)	(N/A)
Printer (typical)	500 mm (18 in)	650 mm (30 in)	200 mm (20 in)	(N/A)
Agilent water chiller	368 mm (14.5 in)	702 mm (27.6 in)	575 mm (22.6 in)	82 kg (181 lb)
SPS 4 Autosampler	600 mm (23.6 in)	363 mm (14.3 in)	510 mm (20.1 in)	15 kg (33.1 lb)

Instrument Shipping Information

System unit	Width	Depth	Height	Weight
SPS 3 Autosampler	490 mm (19.3 in)	285 mm (11.2 in)	510 mm (20.1 in)	15 kg (33.1 lb)
SPS 3 and SPS 4 trolley	580 mm (23 in)	412 mm (17 in)	400 mm (16 in)	8.4 kg (18.5 lb)
Advanced Valve System (AVS) 4, 6 and 7	170 mm (6.7 in)	190 mm (7.5 in)	100 mm (3.9 in)	1.4 kg (3.1 lb)
SVS 2 Plus	54 mm (2.1 in)	110 mm (4.3 in)	177 mm (7.0 in)	620 g (1.37 lb)
Fast Uptake Pump for SVS 2+	122 mm (4.8 in)	170 mm (6.7 in)	97 mm (3.8 in)	0.96 kg (2.1 lb)
VGA (including mounting bracket)	385 mm (10 in)	340 mm (8 in)	195 mm (9 in)	6 kg (13.2 lb)
IsoMist	100 mm (3.9 in)	195 mm (7.7 in)	120 mm (4.7 in)	2 kg (4.4 lb)

WARNING



Heavy Weight

The Agilent ICP-OES weighs approximately 106 kg (234 lb). To avoid injury to personnel or damage to equipment, always use a fork lift or other suitable lifting device when moving the instrument.

Seismic Requirements

If necessary, insert tie down brackets into mounting slots, create corresponding holes in the table, and secure the brackets with bolts.

NOTE

Seismic brackets are not supplied by Agilent. Prepare these items separately.

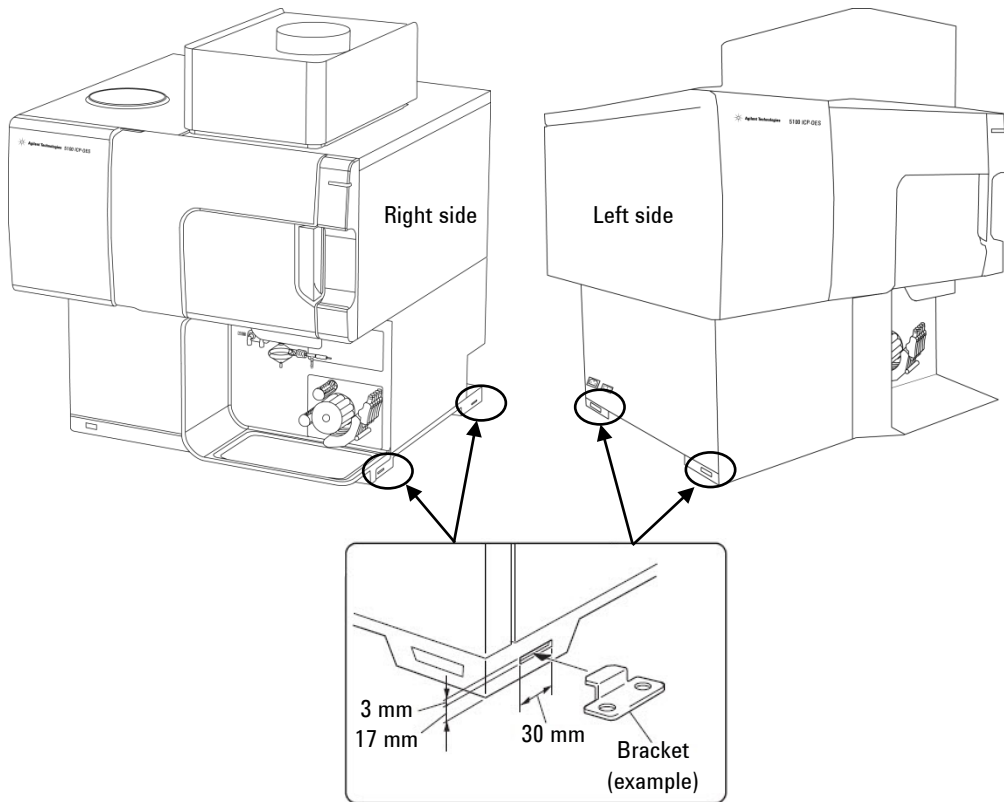
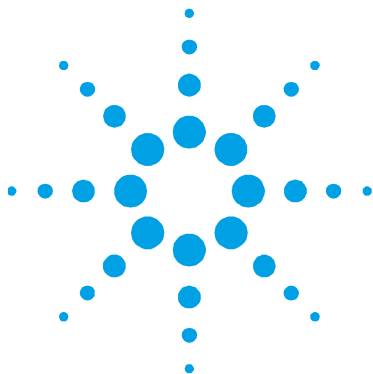

Figure 5. Slots for seismic tie down

Instrument Shipping Information

This page is intentionally left blank.



5. Laboratory Facilities

Exhaust System

The Agilent ICP-OES must be located under a flue that is vented by an exhaust fan and ducted to an external vent.

The exhaust system installation must comply with any rules and/or regulations that may be imposed by the local authorities responsible for control of facilities and fixtures in the work place.

The exhaust system with flue, ducting and external vent requirements are:

- Minimum flow: 2.5 m³/min (90 ft³/min) at 2.4 m/s (7.7 ft/s)
- Maximum flow of 6.0 m³/min (200 ft³/min) at 5.7 m/s (18.6 ft/s).
- The ventilation ducting must have an ID of 150 mm (5.9 inches).
- Flexible ducting must be used for easy removal during instrument maintenance.
- Exhaust flow must be continuous as long as the plasma is on. Exhaust flow must be stable with a maximum fluctuation of ±5% of flow.
- The exhaust fan should be located at least 2 meters (6 ft, 6 in) away from the top of the instrument chimney.
- The fan control switch and running indicator lamp should be located in a position where the instrument operator can view the indicator and access the control switch.

Laboratory Facilities

- Ducting must be corrosion-resistant, fire-proof and should be kept clear of fire alarms, sprinkler heads and other heat sensitive devices.
- The external vent must be fitted with a back draft damper and the outlet location must be clear of doors, windows and heater or air-conditioning units.
- It is recommended to directly connect the exhaust ducting directly via the 150 mm diameter exhaust vent. However if using an extraction hood it is important to closely couple this to the extraction port with a distance of no more than 1.5 cm (0.6 inches) above the exhaust outlet.

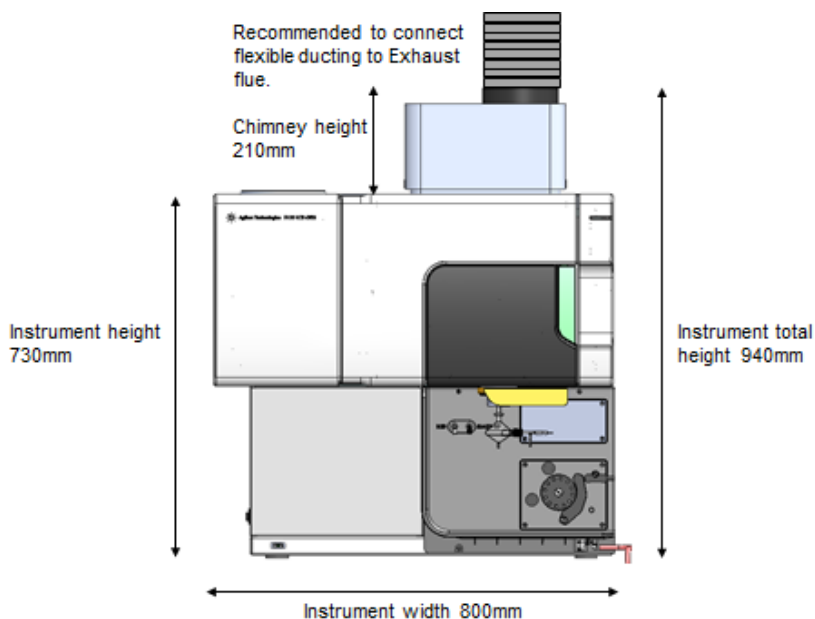

Figure 6. Spectrometer and flue position

The component parts or a kit required for an exhaust system may be purchased from Agilent. Otherwise, the customer is responsible for supplying the ductwork between the instrument and the lab extraction system.

To allow for personal preferences, control gear switch and pilot light assemblies are not supplied by Agilent.

Table 4. Exhaust fan motor specifications

Voltage	240 volts single phase	115 volts single phase
Current	0.45 A	0.7 A
Frequency	50 Hz	60 Hz
Power input	74 W	51 W
Direction of rotation	Anti-clockwise (shaft end)	
Nominal RPM	≈ 1600	



After the exhaust requirements have been met, check the checklist box: *Exhaust system is suitable.*

Electrical Power Supplies

The installation of electrical power supplies must comply with the rules and/or regulations imposed by the local authorities responsible for the use of electrical energy in the workplace.

All power supplies for the Agilent ICP-OES, its accessories and water chiller should be single phase, AC, 3 wire systems (active, neutral, ground; or two active and ground). Each connection should be terminated at an appropriate receptacle within reach of each assembly's power cable. Use of power boards or extension cables is *not* recommended. If the desired location of equipment does not permit the standard power cord to reach an electrical outlet, your electrician should install additional outlets. Otherwise, you should relocate the equipment closer to existing electrical outlets.

The outlet for the Agilent ICP-OES must have a dedicated ground.

It is recommended that separate mains circuits, (individually protected by fuses or circuit breakers) are used for each component in the system such as the water chiller, autosampler and printer.

Avoid using power supplies from a source that may be subject to electrical interference from other services (such as large electric motors, elevators, welders and air conditioning units).

Laboratory Facilities

Electrical Requirements

Table 5. System electrical specifications

System unit	Required supply voltage	Maximum Power Consumption	Nominal rating
Spectrometer	200–240 VAC Single Phase 50 Hz–60 Hz	200-220 V, 15 A 230-240 V, 13 A	2.9 kVA
PC, Monitor, and Printer	100-127 VAC 200-240 VAC	10 A 5 A	1000 VA 1000 VA
G8481A Water chiller	220–240 VAC, 50 Hz 120 VAC, 60 Hz	8.9 A 16 A	2140 VA 1920 VA
G8489A Water chiller	240 VAC, 50 Hz 208-230 VAC, 60 Hz	12.2 A 12.2 A	2900 VA 2900 VA
SPS 4 Autosampler	100–240 VAC, 47–63 Hz, 1.5 A		24 VDC, 2.5 A
SPS 3 Sample Preparation System	100–240 VAC, 50–60 Hz	<1 A	~220 VA
ASX-500 Series Autosampler	85-264 VAC	<1 A	40 VA
VGA 77	100 or 120 VAC, 220 VAC (equivalent to 230 VAC), or 240 VAC (equivalent to 230 VAC)Frequency 49–61 Hz		24 VA
SVS 2+	100–240 VAC, 50–60 Hz		1.8 A
IsoMist	100–240 VAC, 50-60 Hz		2 A

Single phase requirement

The Agilent ICP-OES requires a single phase mains input voltage of between 200-240 VAC (50-60Hz) and draws a maximum of 15 amps RMS at 200 to 220 volts and 13 amps at 230-240 volts (2.9 kVA) with a power factor of approximately 0.99. (Can be a cross phase connection to achieve specified supply voltage).

Power plugs and cords

The Agilent ICP-OES is supplied with a power cord set appropriate for the country from which the order originates. See Appendix A for illustrations of the power cords available.

If necessary, replace the power cord only with a cord equivalent to the one specified (See Appendix A).

CAUTION

If an instrument is being ordered from one location, but is to be installed in another location with different electrical power characteristics, this must be noted on the order. A special note must also be made if the electrical power at the site is different from the standard electrical power in that country.

WARNING



Make sure the power cords supplied with the Agilent ICP-OES are appropriate for your country and site before using them.



After the electrical requirements have been met, check the checklist box: *Specified electrical supply and power outlets installed.*

Gas Supplies

Liquid or gaseous argon and nitrogen may be used with Agilent ICP-OES spectrometer systems. Agilent recommends the use of liquid gases, which are purer, more convenient and cheaper per unit volume. Contact your local authorities and gas supplier for more detailed information on storage requirements for all required gases and also boil-off rates for local types of or Portable Liquid Cylinders (PLC).

Table 6. Gas supply requirements

Component	Gas
Plasma, nebulizer, optics interface purge	Argon

Laboratory Facilities

Component	Gas
Polychromator assembly	Argon or Nitrogen (supplied through optional nitrogen purge kit)

The user (or other authorized personnel) must carry out appropriate leak tests necessary to ensure safety on the gas and liquid connections that the operator is directed to assemble during installation, normal use or maintenance.

Table 7. Argon and nitrogen gas specifications

	Argon GCA 580	Nitrogen (if nitrogen is used to purge the polychromator) CGA 580	Option gas (if required for application) CGA 540
Purity	99.995%	99.995%	99.995%
Oxygen	<5 ppm	<5 ppm	Oxygen 20%, Argon 80%
Nitrogen (argon only)	<20 ppm	-	-
Water vapor	<4 ppm		<4 ppm
Permissible pressure range*			500–600 kPa (73–88 psi)
Recommended pressure*			550 kPa (80 psi) regulated

*When supplying required gas flows

CGA – Compressed Gas Assoc. Standard

Table 8. Typical flow rates for the Agilent ICP-OES instruments

	Argon (with argon purge gas)	Nitrogen (as purge gas)
Standby mode	0.70 L/min	Nitrogen flow 0.8 L/min
Operational range min-max (plasma on)	13.4-26.0 L/min	Argon flow 12.7-22.3 L/min Nitrogen flow 0.8-4.4 L/min

The Agilent ICP-OES is supplied with three PVDF gas supply hose assemblies, each 3 m (9.8 ft) in length fitted with 1/4 inch Swagelok nut and ferrule set.

Fittings for the regulator end must be supplied by the customer. Alternatively, a fittings kit can be ordered from Agilent Technologies. See the Agilent website at www.agilent.com for ordering information.

Customers must provide connection from the gas supply to a shutoff valve.

Customers must provide pressure regulators for the gas cylinders. When ordering, consider the size of the output tubing, 1/4 inch (6.4mm), and also the Compressed Gas Association (CGA) number.

If the Nitrogen Purge option is purchased, additional fittings will be supplied to connect the gas to the ICP-OES.

Laboratory Facilities

If gases are to be plumbed from a remote storage area to the instrument site, ensure that the local outlets are fitted with stop valves, pressure gauges and suitable regulators, which are easily accessible to the instrument operator. The gas outlets must be provided within 1.5 meters (5 feet) of the instrument.



After the gas requirements have been met, check the checklist box: *Gas supply (at specified purity), regulator, and gas lines are installed for argon and optional nitrogen.*

Water Chiller System

Agilent ICP-OES instruments require a source of cooling water. The cooling water is required for the Solid State RF oscillator, load coil, camera Peltier assembly and Axial sample cone interface. The instrument incorporates an in-line particulate filter and water flow sensors on the water supply line.

The Agilent Water Chiller, filled with Poly-Clear Fluid (G3292-80010), can be used and will ensure the continued delivery of temperature controlled coolant, at the correct pressure, with a minimum of long-term maintenance or operational expense.

Distilled water will keep the system clean. Do not use tap water as it will contaminate the system and do not use deionized water as it will corrode the system.

For water chillers not provided by Agilent, consult the documentation that came with it for appropriate coolants. The water chillers must meet the following requirements.

Table 9. Agilent ICP-OES chiller requirements

Cooling capacity	1400 W for dual view instruments, 900 W for radial view instruments
Flow rate	2.0 L/min (0.3 US gallons/min) minimum
Recommended inlet temperature	20 °C (68 °F)
Temperature range	15–28 °C (59–82 °F)
Minimum inlet pressure	230 kPa (33 psi)
Maximum inlet pressure	400 kPa (58 psi)
Conductivity	50-150µS at the chiller reservoir
Connections	Hoses 5 m (16.4 ft) long, 12 mm ID, with 1/2 inch NPT male connectors

NOTE

Pressure regulation is recommended for supplies where the cooling water pressure that may exceed the maximum permissible pressure of 400 kPa (58 psi) or may be subject to pressure fluctuations.

Location

Consult the water chiller's literature for more information before installing.

A 60 cm (24 inch) space must keep clear on the left and right side and above the chiller for enough air flow to allow for sufficient cooling.

The coolant supply and return hoses of the ICP-OES are 5.0 meters (10 feet) in length. The inner diameter of the return hose is 12 mm (1/2 inch). The inner diameter of the supply hose is 12 mm (1/2 inch). The ICP-OES is supplied with 1/2 inch NPT male fittings for connection to the Agilent Water Chiller. It is the customers responsibility to supply appropriate fittings for other chilled water supplies.

Please see the Agilent website for part numbers for ordering additional hose by the meter and clamps: www.agilent.com



After the water cooling requirements have been met, check the checklist box: *Water cooling/circulation system and power connections are set up.*

Waste Fluid Container

The Agilent ICP-OES system needs a drain vessel for disposal of excess fluids and vapors from the spraychamber or autosampler. Suitable tubing is supplied with the spectrometer for use with inorganic solvents. When using organic solvents, different drain tubing that is suitable for the solvent in use will be required.

A chemically inert container, not glass or of a narrow-necked style, to hold a minimum of 2 liters (4 pints) of waste must be provided by the user. It should be located underneath the sample compartment (or on the right side of the instrument), where it is protected by the bench and in full view of the operator.

Contact your waste management facility for information on how to dispose of all spectrometer waste in accordance with local regulatory requirements.



After the waste fluid container requirements have been met, check the checklist box:
Waste container appropriate for the chemical waste is prepared.

Guidelines for Software Installation

Agilent recommends that you purchase a PC as part of the Agilent ICP-OES package. The PC included in the package will come with the appropriate operating system as loaded by the PC supplier.

For instructions on installing the Microsoft Windows operating system, refer to the appropriate manuals supplied with the software. It is the responsibility of the customer to ensure that the operating system software has been installed and is functional if the customer is supplying the PC or the operating system.

NOTE

Agilent will not assume responsibility for loss of data.

The Agilent service engineer will connect the PC to the spectrometer and any factory-approved accessories purchased at installation. Initial instrument software installation is also included as part of the system installation.

This page is intentionally left blank.

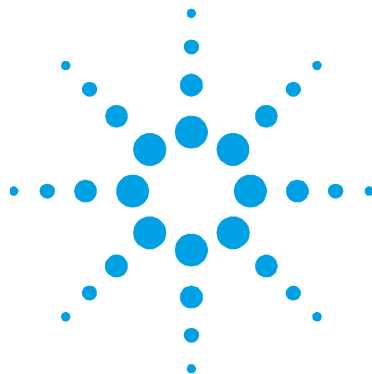

6. Accessories and Options

For detailed instructions and site requirements see the documentation supplied with the accessory.

Vapor Generation Accessory (VGA) Recommended Gases

The VGA is fitted with 6 mm (1/4 inch) internal diameter flexible hose for connection to a standard barbed tail connector, which must be supplied by the customer.

CAUTION

The gas supply for the VGA must be a separate regulated line, to prevent exceeding the maximum inlet pressure to the VGA.

NOTE

The VGA allows a 45 mL/min flow of argon to pass through it even when it is switched off. It is recommended that the argon gas line is fitted with a stop valve to shut off the gas supply to the VGA.

Table 10. VGA gas supply requirements

Permissible pressure range	300–400 kPa (42–57 psi)
Recommended pressure	350 kPa (50 psi)
Required flow rates	Up to 100 mL/min

Important Customer Web Links

- For additional information about our solutions, please visit our web site at <http://www.chem.agilent.com/en-US/Pages/HomePage.aspx>
- Need to get information on your product? Literature Library - <http://www.agilent.com/chem/library>
- Need to know more? Customer Education – <http://www.agilent.com/chem/education>
- Need technical support, FAQs? – <http://www.agilent.com/chem/techsupp>
- Need supplies? – <http://www.agilent.com/chem/supplies>

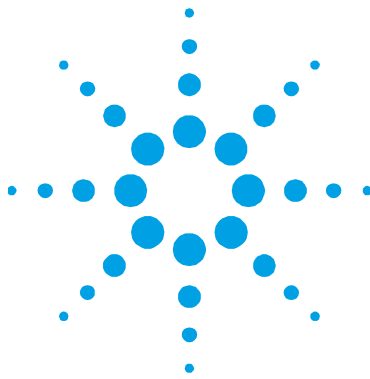

Appendix A: Power Cords

This appendix shows the power cords available for the Agilent ICP-OES system.

The diagrams are for illustration purposes only. The cable that arrives may differ in appearance.

US, Canada, 250 V, 15 A, NEMA 6-15 (Agilent Part Number 8120-8623) Length 2.5 m (8.2 ft)

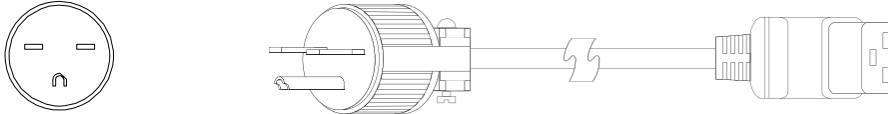

UK, Hong Kong, Singapore, Malaysia, C19, 13 A, BS 1363 (Agilent Part Number 8120-8620) Length 2.5 m (8.2 ft)

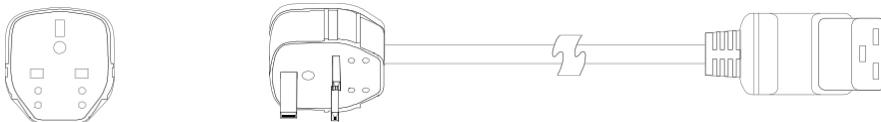

Switzerland, Denmark, C19, 16 A, 1302 (Agilent Part Number 8120-8622) Length 2.5 m (8.2 ft)

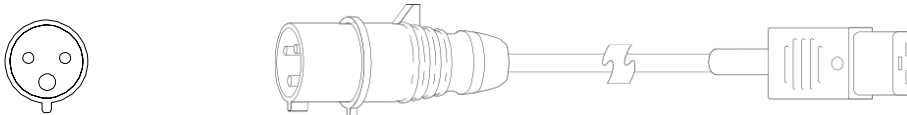

Australia, C19, 16 A, AS 3112 (Agilent Part Number 8120-8619) Length 2.5 m (8.2 ft)

China, C19, 15 A, Fast, GB 1002 (Agilent Part Number 8121-0070) Length 2.5 m (8.2 ft)

Argentina, C19, 16 A, IRAM 2073 (Agilent Part Number 8121-0675) Length 4.5 m (14.7 ft)

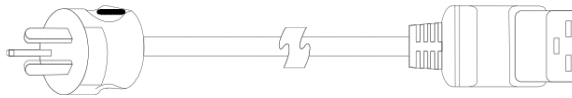

India, South Africa, C19, 15 A, IS 1293 and IS 6538 (Agilent Part Number 8121-0710) Length 2.5 m (8.2 ft)

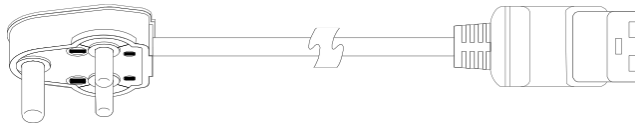
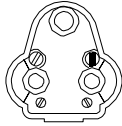

Israel, C19, 16 A, SI 32 (Agilent Part Number 8121-0161) Length 2.5 m (8.2 ft)



Japan, C19, 20 A, NEMA L6-20 (Agilent Part Number 8120-6903) Length 4.5 m (14.7 ft)

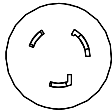

Taiwan, S America, C19, 20 A, NEMA 6-20 (Agilent Part Number 8120-6360) Length 2.5 m (8.2 ft)

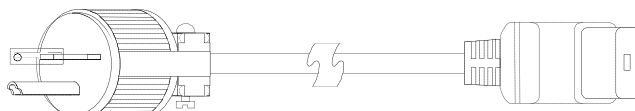
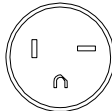

Europe, Korea, C19, 16 amp, CEE7 VII (Agilent Part Number 8121-1222) Length 2.5 m (8.2 ft)

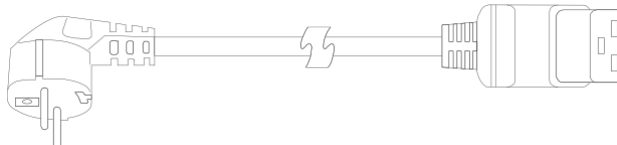
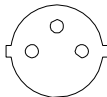

Thailand, 220 V, 15A, 1.8 M, C19, NEMA 5-15 (Agilent Part Number 8121-1301) Length 1.8 m (5.9 ft) (Not Shown)

Brazil, C19 250 V, 16 A, NBR 14136 (Agilent Part Number 8121-1787) Length 2.5 m (8.2 ft) (Not Shown)

Appendix A – Power Cords

In This Book

The manual describes the following:

- Safety Practices and Hazards
- Introduction
- Laboratory Environment Requirements
- Instrument Shipping Information

© Agilent Technologies 2014, 2016, 2017,
2019
02/19



G8010-90001
Issue 5